



INTRODUCTION

The Brodersen RTU32 RTU, PLC and controller series based on a 32-bit platform provides the RTU/PLC with power and leading edge functionality. The platform is based on a fanless industrial PC platform with WinCE 5.0 .NET operating system. It provides an open and adjustable platform with both the power and functionality required to control advanced industrial applications.

Fully equipped with a powerful IEC61131 PLC functionality, web server configuration and real time clock with milliseconds resolution, it provides you with all the advantages the combination of a very fast PLC, IPC and RTU can give you.

The RTU32 is in general based on the flexible hardware layout and design, known from the existing RTU8 and RTU870 product series. It is supplied in a robust aluminium enclosure and can be used with the wide range of Brodersen I/O expansion modules. It is in standard module kept in the modular size of 189mm.

Ethernet and TCP/IP are the basic communication and data environments, however, serial communication interfaces are still an important part of the RTU32 for interfacing to various system parts.

The RTU32 is available with or without integrated I/O. Different software functionality is provided.

Features

- Powerful RTU, PLC and Industrial Controller.
- Open Platform with WinCE Operating System.
- Integrated Powerful EN/IEC61131 Control Software.
- Several Communication Protocols Supported;
 - Full Modbus suite.
 - EN/IEC60870-5-101/103/104 Protocol Support.
 - IEC61850.
 - IEC61400-25.
 - DNP3.
 - ProfiNET .
 - PROFIBUS DP Master.
 - BAC NET.
 - COMLI.
 - Global Distribution and Subscription of Event Based Time Stamped Variables.
 - SMNP agent for network monitoring, alarming etc.
- Dual Ethernet and COM Interfaces.
- Robust Design for Industrial Applications.



VERSIONS/ORDERING CODES

	UCN-26IOA/2	2	1	B	01	30.	D
Type RTU32 PLC / Industrial Controller	UCN						
I/O integration versions RTU32 basic without I/O 16DI/4RO/4AI/2AO	B	26IOA					
CPU Motherboard type 500MHz x86 CPU		2					
RAM/Flash size 128MB RAM/Minimum 128MB Flash 128MB RAM/128MB Flash/ 1MB non-volatile RAM		2					
		3					
Special options Standard configuration			1				
Branding Brodersen	B						
COMs options COM1, 2:RS232 COM1, 2, 3, 4, 5, 6: RS232 COM1,3,4,5,6: RS232, COM2:RS485 COM1: RS232, COM2: RS485 COM1,2: RS232, PROFIBUSDP M COM1: RS232, COM2:RS485 & PROFIBUSDP M					01 02 03 04 05 06		
Power supply option 115-230VAC/DC, ext. 12VDC 115-230VAC/DC, UPS&12VDC supply 24-48VDC, ext. 12VDC supply						10 20 30	
I/O options No IO type Analogue input/output range: Configurable AI/AO range DI standard 10-30V DC DI Optional ranges of up to 72VDC							0 D

Driver runtime license details:

RTU32 are delivered with a range of standard drivers that includes full Modbus suite, IEC60870 suite STRATON Binding and COMLI Master.

For additional drivers a runtime driver license has to be ordered separately.

The available driver licenses are;

Order code	Description
DL-IEC61850S-RL	IEC61850 Server driver with GOOSE/MMS
DL-IEC61850C-RL	IEC61850 Client driver
DL-SNMP-RL	SNMP Agent driver
DL-SNMPBC6000-RL	SNMP Agent driver without STRATON PLC
DL-PROFIBUSM-RL	Profibus DP Master driver
DL-PROFINETC-RL	Profinet Client driver
DL-DNP3S-RL	DNP3 Slave Serial/Ethernet driver
DL-DNP3M-RL	DNP3 Master Serial/Ethernet driver

Our range of drivers are developed all the time - ask if your driver is missing or have special requirements. Special versions can be delivered as option. Contact us for more



CONTENT

Introduction	1
Introduction text	1
Module	1
Version/Ordering code	1
Technical Description	3
Input/Output	3
Wiring Diagram UCN-B/xx	3
Wiring Diagram UCN-26I/O	4
General	5
Configuration	5
I/O's and Database	5
STRATON SoftPLC	5
I/O Drivers	5
Fieldbus Configurator	5
EN/IEC60870-5-101/104	5
Data Logging	6
Modem Control	6
Real-Time / Real-Time Clock	6
COM communication for NullModem, radio and LeasedLine modems	6
Power supply options	6
Other interfaces	6
RTU32 combined power supply and battery charger (UPS)	6
Power consumption/Power budgets	7
Batteri performance/application example	8
Peak power for short time	8
Technical Data	9
Basic 32-bit system	9
CPU	9
BIOS	9
System chipset	9
System memory	9
Non volatile RAM	9
SSD	9
Watchdog timer	9
Physcial Interfaces	9
Dual Ethernet	9
COMS	9
USB	9
VGA/LCD	9
PS/2	9
I/O Expansion	9
Industrial I/O	9
Expansion I/O	9
Integrated I/O	9
Integrated Digital I/O	9
Inputs	9
Isolators	9
Indicators	9
Integrated Relay Outputs	9
Relay Outputs	9
Lifetime (relay)	9
Contact material	9
Isolation	9
Indicators	9

Integrated Analogue Input	9
Inputs	9
Input Configuration	9
Input measuring ranges	9
Resolution	9
Impedance	9
Absolute maximum ratings	9
Update time	9
Measuring accuracy	9
Linearity	9
Temperature stability	9
Common mode voltage	9
Common mode ratio	9
Series mode rejection	9
Isolation	9
Integrated Analogue Output	10
Outputs	10
Output ranges	10
Resolution	10
Absolute maximum ratings	10
Update time	10
Accuracy lout	10
Linearity	10
Leakage current	10
Temperature stability	10
Accuracy Vout	10
Isolation	10
Software	
Operating system	10
EN/IEC61131 SoftPLC	10
Standard drivers	10
Optional drivers	10
Power Supply	10
Power supply versions	10
Power consumption	10
Isolation	10
General	10
Indicators	10
Ambient temperature	10
EMC	10
Climatic	10
Mechanical	10
Protection	10
Mounting	10
Housing	10
Dimensions	10
Code Switch/Address Selector	11
Circuit Configuration (Digital)	11
Circuit Configuration (Analogue)	11
Notes	11



TECHNICAL DESCRIPTION

Input/output

The RTU32 basic I/O fit can include 26 input/outputs. Option available:

Version	UCN- 26IO	
Digital inputs (10-30V DC)	16	Can also be used as S0 counter inputs (ZI)
Digital outputs (PNP o. c.)	0	
Analogue inputs (Configurable)	4	
Analogue outputs (Configurable)	2	Sourced outputs
Relay outputs (NO)	4	

All digital I/O's are equipped with opto-couplers. The analogue inputs have galvanic isolation between the individual channels. Solid state relays are used for multiplexing the analogue inputs. No isolation on analogue outputs.

Wiring diagram

UCN-B/xx

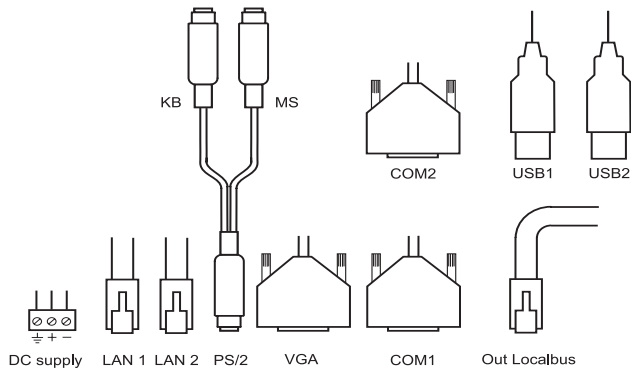

Application I/O



Wiring diagram
UCN-26IOA/xx

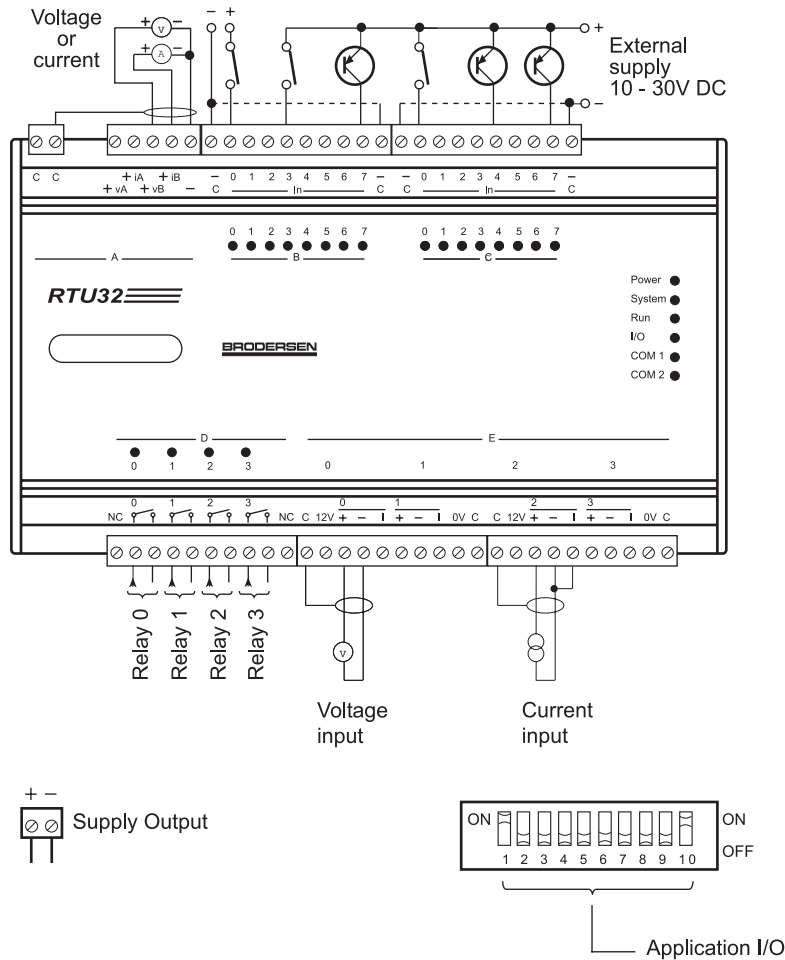
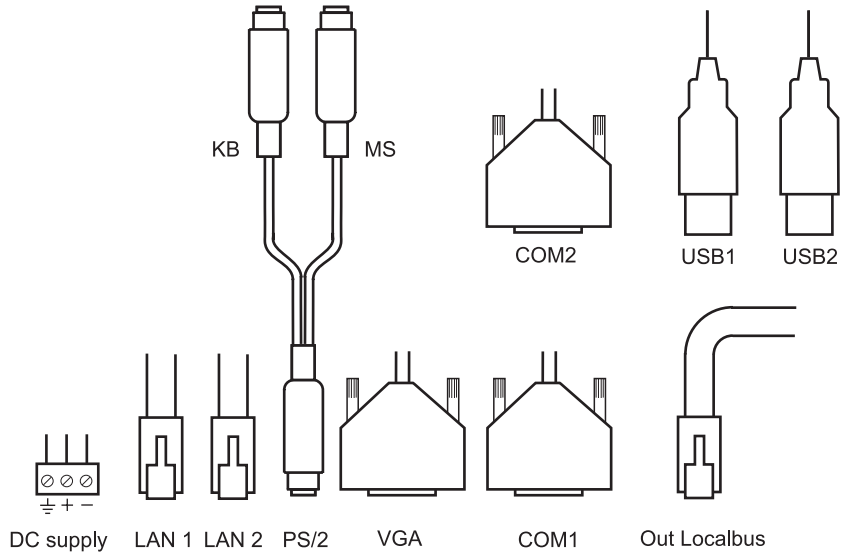



TECHNICAL DESCRIPTION

General

The RTU32 offers 2 main functions:

- A powerful stand-alone RTU/PLC with I/Os to perform embedded data processing, data control/gateway, data logging and monitoring.
- A networking communicator for collecting, managing and communicating data via protocols on different physical interfaces upwards and downwards in industrial applications.

The RTU32 RTU/PLC Outstation and Industrial Controller is based on an Industrial PC platform running WinCE operating system with all the well known embedded Microsoft environment facilities. A range of industrial power supplies is integrated to support industrial supply levels and functions such as UPS. The basic IPC includes a range of communication and other interfaces. The RTU32 provides additional interfaces like LocalBus for expansion I/O and other COMs via the internal PC104 interface.

The RTU32 software is stored on a removable Flash. During start-up, the operating system and applications are moved to RAM where it is executed. System configuration settings are stored on the Flash. Retained variables can be stored on non-volatile RAM or flash when required.

WinCE is the RTU32 Real Time Operating System. Integrated I/O and LocalBus for external I/O connectivity are controlled in an implemented I/O database. A STRATON PLC VM (Virtual Machine) is ported to the WinCE real-time task. This enables the STRATON PLC runtime application program to be executed in the RTU32 - providing very powerful RTOS performance.

Using the Ethernet network for primary communication provides all the advantages of existing TCP/IP networking communication facilities (FTP, HTTP etc). Fast, reliable and secure communication are the main features and all networking components (software, routers, switches, etc.) are available. In addition, serial ports for interfacing to application specific protocols (e.g. Modbus, Fieldbus, utility protocols, network management and traffic proprietary protocols etc.) are available.

Configuration

RTU32 main settings, such as network settings, time settings and other basic configuration parameters, are configured via the RTU32 WebPages.

The main configuration also includes;

- Basic PLC mode settings
- Built-in I/O settings/actual configuration
- Real time clock settings / SNTP
- SNMP agent
- Redundancy
- Remote secure protocol

I/O's and Database

Internal I/O and expansion I/O are managed in an independent database. The I/O database structure is designed as a multi-accessible database. The database runs in its own task providing fast and reliable I/O communication. The STRATON PLC has drivers to access the database both at board level where the I/O is accessed in I/O sections, and in single level where each I/O can be accessed individually according to the specific application requirement.

In addition, an API for WinCE provides access to the database from your own C#, C++ or VBA application. It can even be used as gateway access to a STRATON application program.

STRATON PLC

The STRATON .IDE/WorkBench programming tool fully supports EN/IEC61131 and is used for making PLC programs in the RTU32. The application program kernel is implemented and runs in WinCE real-time task. STRATON offers complete PLC functionality and supports all features needed in today's industrial environment. STRATON supports programming languages such as Structured Text, Function Block, Ladder, Instruction List and Sequential Function Chart. The STRATON PLC supports cold restart, hot restart and on-line changes.

The STRATON Workbench is used for configuration protocols, programming and debugging. It supports several tools for multi-program handling and documentation. It is also a powerful tool for complete system design and programming, providing unique functions for event based communication. The Global Binding Editor makes it possible to publish and subscribe variables in a large network with minimum communication load. The events are time stamped and can also be used directly in ZenOn SCADA HMI applications. Programming, debugging and upload and download of application programs can be done remotely via Ethernet or RS232.

The basic drivers and protocols available for the RTU32 are:

- I/O drivers for integrated I/O and I/O Expansion.
- ModbusRTU Master and Slave.
- ModbusTCP Client and Server.
- EN/IEC60870-5-101 Master and Slave.
- EN/IEC60870-5-104 Client and Server.
- SNMP Agent driver.
- PROFIBUS DP Master.
- BAC NET.
- PROFI NET client.
- IEC61850 MMS/Goose
- IEC61400-25 MMS
- DNP3
- COMLI
- Distributed eventbased binding etc.

I/O Drivers

The RTU32 I/O can be accessed in 2 ways, either as boards (I/O is reported in sections as they are connected physically) or as profiles (each I/O is directly addressed). I/O status is reported in a function block. The I/O driver support up to 32 I/O expansion modules - and more than 1000 I/Os.

SOE Driver (Sequence Of Event)

SOE driver for sequence of event data is provided for fast recording of events at digital inputs. The SOE provide event recording with time stamps and status information. In addition the SOE driver support advanced filter functions for debounce and chatter filtering.

Fieldbus Configurator

With the Fieldbus Configurator Tool in STRATON, the Modbus suite of protocols can be configured. It is also possible to publish or subscribe any variables in RTU32 networks or on other STRATON runtime platforms and ZenOn HMI platforms.

EN/IEC60870-5-101/103/104

Utility protocols EN/IEC60870-5-10x provide full configuration flexibility of almost any interoperability requirements. The protocol links are provided as a driver in STRATON and the application layer data and protocol structures are generated in Structured Text (ST). This gives full access to set up any Interrogation and ASDU required for the application.

In addition, the protocol drivers support advanced features for gateway functions where, for example, information in monitor direction can be



moved from one protocol interface to another without compromising the actual value and original time stamp. Also sharing data queue from more ports are possible.

To simplify and provide fast configuration a RTU32 IEC60870 configurator are available. See the IEC60870 Configurator for details.

Data Logging

A special data logging function block is available for logging event based or cyclical data to the flash file system. The data logging also supports functions for formatted log directly exportable to ZenOn HMI and SCADA software. Log files can be downloaded from the RTU32 via FTP.

Modem Control / Dial-up / Dial-in

Both dial-up and dial-in functions via a PSTN, ISDN or GSM modem connected to the serial port of the RTU32 are possible when using the STRATON modem function. It can be used for any serial communication e.g. ModbusRTU and EN/IEC60870 serial protocols.

Real-Time / Real-Time Clock

The WinCE real-time task is used for the application program execution. Time stamps and cyclic execution are also based on the WinCE real-time clock. Time stamps are reported in milliseconds. In order to achieve high time accuracy the clock has synchronisation option with SNTP and special clock slave and master function for synchronisation from RTU32 to RTU32.

COM communication for NullModem, radio and LeasedLine modems

The RTU32 has implemented extended necessary data communication features for communication of ModbusRTU, serial EN/IEC60870-5-101 etc. over serial modems and converters. The features cover detailed handshake control with timing of RTS and CTS.

Power supply options

The RTU32 can be delivered with some different built-in power supplies. Option for 24-48VDC and 110-240VAC/DC is available. In addition the mains version can be delivered with an UPS for connecting a battery. If the mains is disconnected the RTU32 will continue to run on the battery. Som internal I/O for mains alarm is provided. When the main comes back, the battery is charged and will be standby fully charged for fall back situations next time the mains is interrupted.

The power supply also provide an 12VDC output for used for I/O control.

Other interfaces

The RTU32 include also 2 USB ports for use for mouse, keyboard, Flash disc storage etc.

A VGA port for connecting a monitor and the mouse/keyboard connection provide possibility for work with the RTU directly on the WinCE user interface.

RTU32 combined Power Supply and Battery Charger (UPS)

General

The RTU32 can be delivered with an integrated UPS which is a combined switch mode power supply and an intelligent charger circuit, able to charge and monitor an external lead acid battery.

The battery for UPS function can be an 8 to 36 Ah battery, depending on the actual load and the required backup time. The actual backup time can be calculated from the average consumption of the modules installed (RTU32 and expansion module(s)) and the capacity of the battery used. As the power supply has a current limiter, the recharge time will depend on the size of the battery and the average current used for the electronic circuits.

The following outputs/voltages are derived from the RTU32 power supply:

- Mains supply input 115-230VAC/DC.
- Supply for the CPU board and other electronics and interfaces in the RTU32 module itself (3/5V).
- 12V output for I/O Expansion modules (LB/ELB), 8/10 pole modular jack.
- 12V output for I/O activation, 2 pole plug-in screw terminal.
- 12V output for analogue input loop power supply (on I/O board).
- Battery connection, charging current up to 2.0A, 2 pole plug-in screw terminal.

The maximum current supplied from the power supply to the battery and electronic circuits is 2,2A@12VDC.

In general the RTU32 power supply is monitored and controlled by a microcontroller. It manages parameters like voltage levels monitoring, error handling, status reporting to application etc. In addition the microcontroller handles enhanced watchdog functions.

Relevant monitor parameters from the UPS are available in a STRATON FunctionBlock. It provides info about;

Charger:

Charger is present at RTU.

If Charger=0 the RTU32 is not equipped with a UPS and the rest of the indicators mentioned below equal 0.

MainsErr:

Mains supply is missing. When MainsErr=0 the Mains is still ok.

BatFull:

Battery is 70 to 100 % charged. Indicate when battery is fully charged. Is used for monitoring if the battery is getting bad. If the battery will not enter into state BatFull=1 under normal Mains operation the battery is most likely derated or bad for some reason and require replacement.

BatLow:

Battery low warning (11.0V). Battery low voltage warning is given when the battery is almost discharged and the battery level is reached 11.0VDC. When the mains is back and charging is in process, the BatLow will return to normal after a short while. The indicator allows the application programme to issue a warning and close down before loosing operation. The run time left after getting a BatLow alarm depend on the capacity of the battery and load – and will typically be from 10-20 minutes.

To prevent damaging the battery by deep discharge, the battery will automatically be disconnected and the operation will stop, without any further warning, if the battery voltage goes below 10,4V.

The close down is simply a power cut. If your application need an emergency shut down, you must handle it in the STRATON application program.



BatErr:

Indicate if battery is missing or bad. The battery error will report if the battery is disconnected or a wire or fuse is broken.

Note that if the battery for some reason is derated, the battery error may not be able to detect it. It is a good idea to also monitor that BatFull will be active after mains has been active for a longer time and the battery is expected to be fully charge. If the BatFull never is activated it can also indicate battery error.

BatV:

Battery voltage. The battery voltage can be read by the application program as a real value. It is provided if the user wants to make special application specific warning and alarm levels. Example could be if the battery also supplies a radio that requires some levels of available start-up current to send mains alarms to central station. In this case the user can issue an earlier warning when there is still enough power on the battery to power up the radio.

Power consumption / Power budgets

In order to define battery size and design application program for an application with UPS, it is required for the user to create a power budget. And for this an understanding of the RTU32 power consumption is required.

Power consumption is directly related to the RTU32 hardware configuration and the number of external devices connected to the RTU32. Especially the number of I/O Expansion modules will influence the power consumption.

To increase the lifetime for both RTU32 and battery it is necessary to have a certain amount of power to charger the battery. Power not used by the actual hardware configuration will be used to charge the battery and it is in all interest to keep the charging time as short as possible.

Below are current consumption figures for the standard RTU32 versions. All figures are presented typical consumption mA@12V. The additional current for I/O Expansion modules can be found in the relevant data sheets.

RTU32 version	UCN-26IOA w/6COM		UCN-26IOA std.		UCN-B/XX	
	typical*)	max.	typical*)	max.	typical*)	max.
Basic RTU	700	1200	700	1200	700	1200
26IO board	100	170	100	170	0	0
12V output load:						
Wetting 16DI	35	80	32	80	0	0
Loop power 4 AI	50	85	50	85	0	0
Add. 4xCOM	100	200	0	0	0	0
I/O LocalBus	300	500	300	500	300	500
Total 12V consumption (mA):	1285	2235	1185	2035	1000	1700
Left for charging battery (mA):	915	465	1515	665	1700	1000

*) typical configuration with RTU32 and 2 expansion I/O modules connected and 50% activation of I/Os.



The mains power supply will, until the battery is fully charged, work as a constant current source limited to 2200mA. The electronic circuits (RTU32 and expansion modules) will draw their required current and the remaining current will be used to charge the battery. The load from the I/O Expansion modules must NEVER exceed 600mA in application with UPS, as rest capacity for battery charging is required.

Battery performance / application example

Below are shown examples based on the above calculations for the 3 sizes of batteries. All figures are typical. The calculations assume that the battery is fully charged or fully discharged using the RTU32 charger circuit. Also it is assumed that the average load is constant during test (both charge and discharge periods). Estimated figures are for ambient temperature of 20-25deg. Cel.

RTU32 Configuration 1

UCN-2610A w/6COM with 2 I/O Expansion modules using 300mA@12V
Typical consumption = 1285mA@12VDC

Battery size in Ah:	12Ah	17Ah	28Ah
Backup time *)	9,3h	13,2h	21,7h

Recharge time *)	8,5h	12,0h	19,8h
------------------	------	-------	-------

RTU32 Configuration 2

UCN-B/XX with 2 I/O Expansion modules using 300mA@12V
Typical consumption = 1000mA@12VDC

Battery size in Ah:	12Ah	17Ah	28Ah
Backup time *)	12,0h	17,0h	28,0h
Recharge time *)	7,1h	10,0h	16,5h

*) The figures above assume nominal values for the battery. In reality the figures could degrade dramatically as the performance of a battery may vary widely with temperature and age. If a high degree of security is required, it is strongly recommended that these figures are viewed very conservatively. At high or very cold ambient temperature the recharge time will be prolonged.

You must observe the battery specifications closely and observe lifetime and environmental parameters. This will have impact on the maintenance procedures and schedules for you application using UPS.

Peak power for short time

If you need a higher current capacity for a short time than the RTU32 power supply can deliver, it is recommended to connect the device directly to the battery. If could e.g. be a Radio transmitter or satellite modem.

Typical charge / discharge cycle

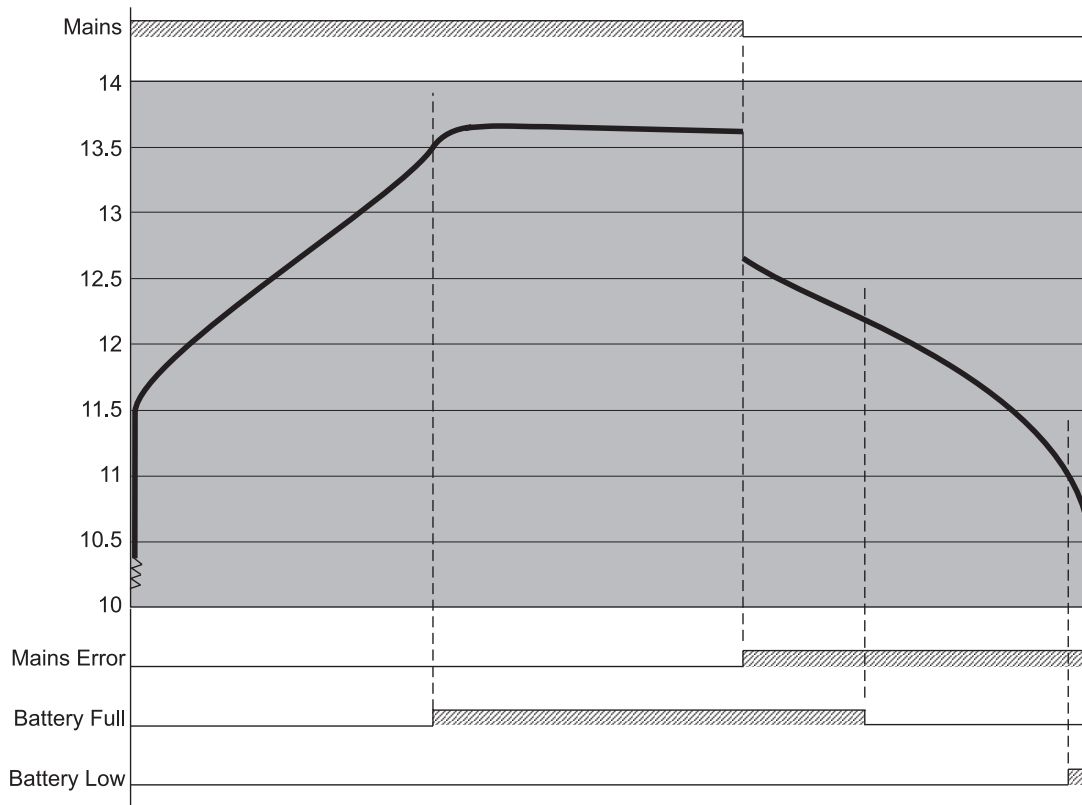



TECHNICAL DATA

BASIC 32-BIT CPU SYSTEM

CPU:	Onboard AMD Geode™ LX800 @ 0,9W 500 MHz with 128K L2 cache
BIOS:	AWARD 512KB Flash BIOS
System chipset:	AMD Geode™ LX800 / CS 5536.
System RAM memory:	One 200-pin SODIMM socket supports up to 1 GB DDR 333/400 SDRAM.
Non volatile RAM (optional):	1MB battery backed RAM.
Disc / SSD:	Min. 64MB removable Compact Flash in Type I/II socket. Support up to 512MB.
Watcdog timer:	Reset: 1 sec. - 255min. and 1 sec. or 1 min./step.

PHYSICAL INTERFACES

Dual Ethernet:	2 x LAN: Dual Realtek RTL8101L.
COMS:	1 x RS232 and 1 x RS232/RS422/RS485
USB:	2 x USB 2.0 ports.
VGA/LCD:	PCI bus VGA/LCD interface
PS/2:	Single interface for keyboard and PS/2 mouse. Twin interface cable included.
I/O Expansion:	RJ45 LocalBus interface for Brodersen I/O Expansion modules. See industrial I/O sec- tion.

INDUSTRIAL I/O

Expansion I/O:	Expansion I/O is possible via the Brodersen I/O LocalBus system to all Brodersen I/O Expansion modules. Supports up to 32 I/O Expansion modules of any type.
----------------	--

NOTE: On RTU32 without UPS it can supply max. 1000mA for supply of I/O Expansion modules. For RTU32 with UPS the max. load is 500mA

Integrated I/O:	26I/O board integrated supports; 16 Digital inputs 4 Relay outputs 4 Analogue inputs 2 Analogue outputs. Scantime better than 5ms for digital I/O for smaller applications.
-----------------	---

INTEGRATED DIGITAL I/O

Inputs:	
Input voltage activated:	10-30V DC.

Input delay:	Typical 1ms.
Isolation:	2kV AC
Indicators:	One LED for each digital input (red) indicat- ing active input.

INTEGRATED RELAY OUTPUTS

Relay outputs:	4 potential free SPST-N/O contacts.
Output voltage:	Max. 240V AC.
Output current:	Max. 1A AC (resistive).
Output delay:	Typical 5ms.
Lifetime (relay):	Min. 100.000 operations at rated load.
Contact material:	Gold overlay silver alloy.
Isolation (coils-contacts):	2kV AC 50Hz 1 min (IEC255-5). 4kV 1,2/50micro s. / impulse withstand (IEC255-5).
Indicators:	One LED for each output (yellow) indicating active output.

INTEGRATED ANALOGUE INPUT

Inputs:	4 multiplexed analogue channels with solid state multiplexer.
Input configuration:	Differential (+/-), flying capacitor type.
Input measuring ranges:	0 - 10V 0 - 5V -5 - +5V -10 - +10V 0-2V/0 - 20mA 0,4-2V/4 - 20mA Selection between these ranges shall be done on Web configuration.
Resolution:	14 bit, 0-16383.
Impedance:	Voltage: 1M Ohm. Current: 100 Ohm ±0,25%.
Absolute maximum ratings:	Input voltage: ±15V DC. Input current: ±30mA DC.
Update time:	Better than 250 ms.
Measuring accuracy:	25°C: ±0.1% (typically 0.05%). -10°-55°C: ±0.3% (typically 0.1%).
Linearity:	Better than ± 0,05%.
Temperature stability:	Better than ± 50ppm/°C (typical).
Common mode voltage:	Max. ±80V DC.
Common mode rejection ratio:	Min. 72dB.



Series mode rejection: Min. 36dB (50-120Hz)

Isolation: (input to input): 500V.

INTEGRATED ANALOGUE OUTPUT

Outputs: 2 sourced analogue channels.

Output ranges: 0 - 10V
0 - 5V
-5 - +5V
-10 - +10V
0 - 20mA
4 - 20mA
Selection between these ranges can be done in web config or STRATON.

Resolution: 14 bit, 0-16383.

Absolute maximum ratings: Iout: Output voltage: 27V DC.
Load: 1kOhm
Output current: 25mA DC.
Vout: Output voltage: ±15V
Load: 1kOhm

Update time: Better than 100 ms.

Accuracy Iout: 25°C @ 100Ohm: ±0,1%
-10°-60°C @ 100Ohm: ±0,2%

Linearity: Better than ± 0,05%.

Leakage current: Max. 10 µA (typically 3µA)

Temperature stability: Better than ± 50ppm/°C, @ 100Ohm.

Accuracy Vout: 25°C: ±0.1%
-10°-60°C: ±0.2%

Linearity: Better than ± 0,05%.

Isolation: (input to input): No isolation.

SOFTWARE

Operating system: WinCE 5.0 .NET.
Open platform with possibility for developing and running customer application.

EN/IEC61131 PLC: STRATON PLC VM Embedded runtime.

POWER SUPPLY

Supply Voltage versions: 24-48VDC (20-60VDC).
115-230VAC/DC (90-265VAC/DC).
115-230VAC/DC (90-265VAC/DC) with UPS and battery charger 12VDC.

Power consumption: Max. 40W and typical 16W - Configuration dependent.

Isolation: Power supply to electronics: 3750V

Max loads: LocalBus (for supply of I/O Expansion modules) are 1000mA for standard power supply versions and 500mA for UPS power supply version.

12VDC output: max load 200mA

GENERAL

Indicators (LEDS):
Power (green): Indicating power ON.
System (green): Indicate system status.
Run (green): Indicate SoftPLC program status.
I/O (green): Indicate status of integrated and expansion I/O.
Com x (yellow): Indicate Rx/Tx activity on the specific com port.

Ambient temperature: Storage: -40 - +85°C
Operation: -10 - +60°C.
(Optional: -25 - +70°C - See note 1)

EMC/LVD: EN55022:1998 Class A
EN61000-3-2:2000
EN61000-3-3:1995
EN55022:1998 Class A
EN55024:1998 (EN61000-4-2:1995,
EN61000-4-3:1996, EN61000-4-4:1995,
EN61000-4-5:1995, EN61000-4-6:1996,
EN61000-4-8:1993, EN61000-4-11:1994)
EN 61000-6-2: EMC/ Immunity Industry.
EN 61010-1: Safety requirements for electrical equipment for measurement and control.

Climatic:
Dry heat: IEC 68-2-2, Test Bd, Temp. +55°C,
Duration 8h.
Cold: IEC 68-2-1, Test Ad, Temp. -10°C,
Duration 8h.
Damp heat: IEC 68-2-3, Test Ca, Temp. 40°C, RH
95%, Duration 8h.

Mechanical:
Vibration: IEC 68-2-6, Test Fc (sinusoidal), Freq.
10-150Hz, Amp.4g, 5 sweeps in 3 orthogonal axes.
Shock: IEC 68-2-27 (half sine), Acc. 15g, Pulse
time 11msec., 3 x 6 shocks.

Protection: IP20.

Mounting: 35 mm DIN-rail, EN50022.

Housing: Black aluminium housing.

Dimensions: HxWxD: Standard: 94(+connectors)x189x101 mm.
Other dimensions depending on configuration.



CODE SWITCH/ADDRESS SELECTOR

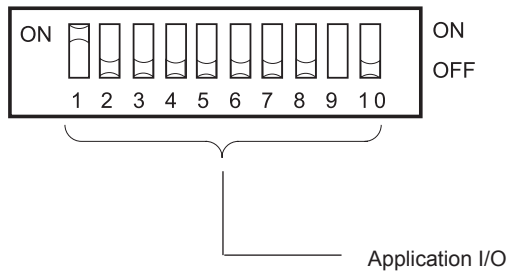

The DIL switches can be read from the STRATON application program and can be used for simple end user configuration.

CIRCUIT CONFIGURATION (DIGITAL)

Input

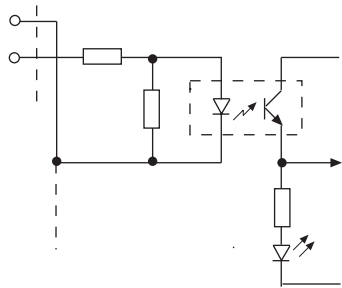

Output (PNP type only)

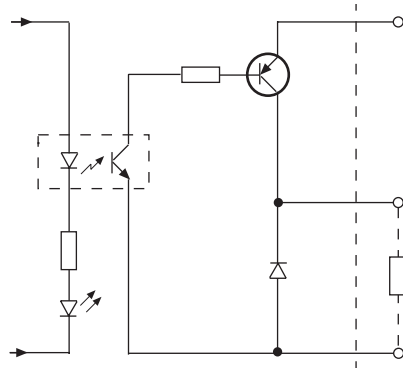

CIRCUIT CONFIGURATION (ANALOGUE)

Analogue Input

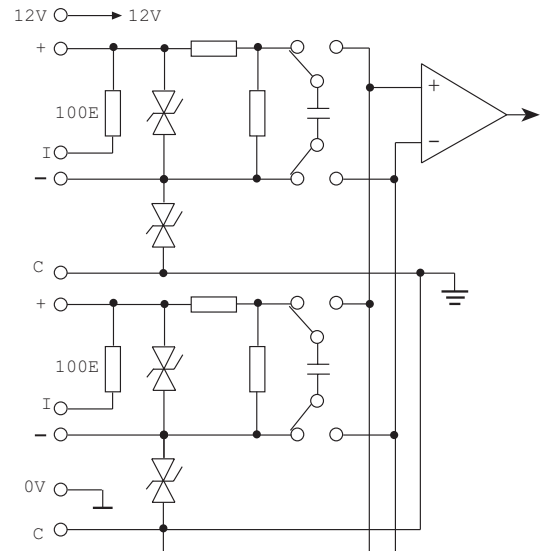

Analogue Output

I Out

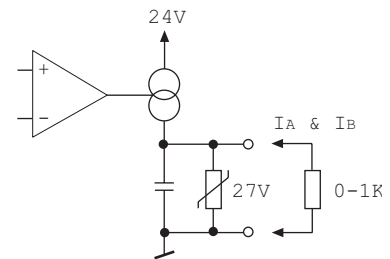

V Out

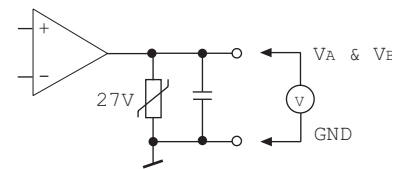

NOTES

Note 1:
Extended operating temperature range can be delivered as an option.
Please contact us for details.